



Outdoor Water Resistant AI PoE Switch

MSW-3208GP-2GL-120I-OD Product Features

- Total 120W Power Supply
- 8 ports PoE
- 2 ports Uplink
- 2 ports SFP
- AI Watchdog Function
- 6KV Lightning & 8KV ESD Protection
- Support bt 60W High Power

Specifications



Dimension (mm)

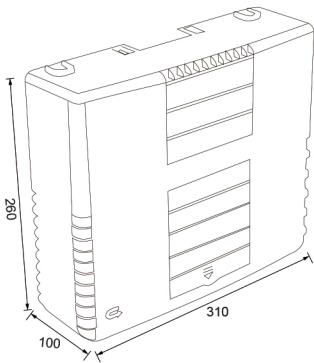

Installation Diagram



Model	MSW-3208GP-2GL-120I-OD
Ports	PoE (1~6):10/100/1000Mbps PoE ports (RJ45) PoE (7~8):10/100/1000Mbps PoE ports (RJ45),Support bt 60W High Power LAN(1~2):10/100/1000Mbps uplink ports (RJ45) SFP(1~2):10/100/1000Mbps SFP ports
Transmission Rate	2000Mbps Full Duplex; 10 or 100 or 1000 Mbps Half Duplex
Transmission Distance	130m
Performance Specification	Bandwidth:24Gbps
	Network Latency (10 to 1000Mbps): $\leq 16\mu s$ (use the 64byte package size)
	MAC address table: 8K
	The Frame Filter & Transmission Rate: 14800pps the most for 10M port, 148800pps the most for 100M port;1488000pps the most for 1000M port
Networking Standard	IEEE 802.3i 10BASE-T/IEEE 802.3u 100BASE-TX
	IEEE 802.3ab 1000BASE-T
	IEEE 802.3x Flow Control
	IEEE 802.3af/at/bt Power over Ethernet
Power Support	Power Input: AC 90~240V Total $\leq 120W$ AI Watchdog: Port 1~8 Power Output: PoE1~6 Port:1/2(+52V),3/6(GND) $\leq 30W$ PoE7~8 Port: 1245(+53V),3678(GND) Compatible1/2(+52V),3/6(GND) $\leq 60W$
Protection Level	Lightning Protection:6KV, Per: IEC61000-4-5 ESD Protection:8KV, Per: IEC61000-4-2
Physical Specifications	Size(L*W*H): 310mm*260mm*100mm, Weight: 1.6KG
Working Environment	Operating Temperature: -30 C ~60 C
	Storage Temperature: -40 C ~70 C
	Operating Humidity: 10%~90% Non-condensing
	Storage Humidity: 5%~90% Non-condensing
Certification	CE Mark
	FCC Part15,Class B
	RoHS 2.0
Guarantee	25 months
Package Content	AC Power Cable,User Manual